

# 50L HELIX Oscillating Biomixer® 83B Cap

The Lifecycle HELIX Oscillating Biomixer® is the right choice for a wide variety of applications, including where the need for autoclave or gamma sterilization is necessary for the container. Features include:

- Cost effective Bioreactor
- Media Manufacturing
- Chemical Blending
- Tissue Cleaning
- Wet Powder Size Reduction
- Cell Disruption
- Filler Staging
- Chemical and Cell Storage
- Pre-blends Holding
- Tissue Cleaning

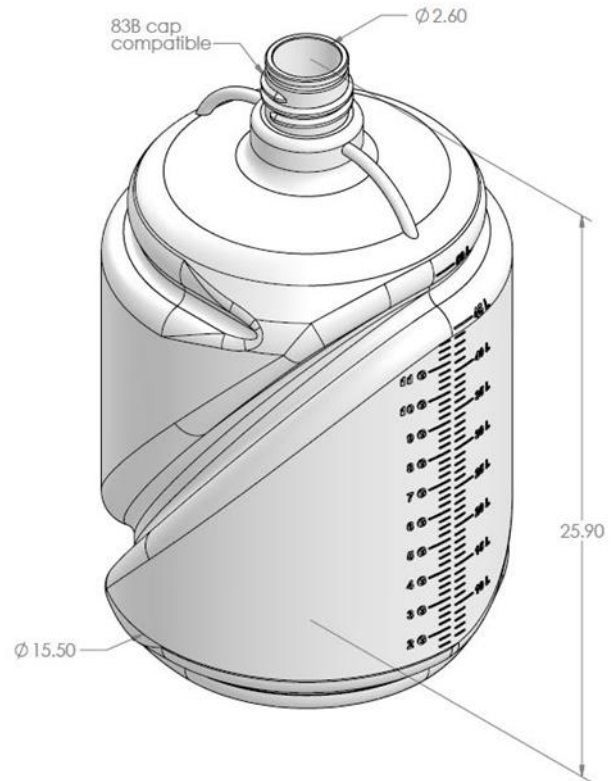

Catalog Number:	100172A
Unit Size:	1 Boxed Container
Capacity (English):	13.2 gal.
Capacity (Metric):	50L
Closure Material:	Polypropylene, Class VI
Closure Size:	83B
Description:	50L Polypropylene Oscillating Biomixer w/Handles
Diameter (Metric) Outer:	394 mm
Autoclavable:	YES
Color:	Translucent (NO added colorant)
Material:	Polypropylene, Class VI

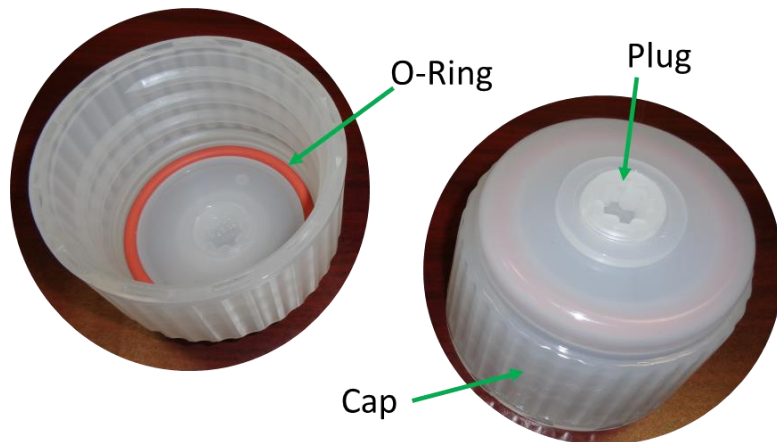

- 83B cap, standardized design
- Cap includes 3/4" threaded opening
- Cap comes with plug that provides flat surface on inside of cap.
- Cap and Plug made from same Polypropylene material
- Natural translucent appearance, NO colorants added
- Standard FDA Silicone O-ring provided
- Optional USP VI translucent silicone O-ring available